

160–162 °C (MeOH-Et<sub>2</sub>O): <sup>1</sup>H NMR (CDCl<sub>3</sub>, 400 MHz) δ 7.96 (1 H, s), 6.91 (1 H, dd, *J* = 2.2, 8.5 Hz), 6.88 (1 H, d, *J* = 8.5 Hz), 6.85 (1 H, d, *J* = 8.5 Hz), 5.12 (1 H, m, *W*<sub>1/2</sub> = 20 Hz), 4.20 (1 H, dd, *J* = 8.8, 8.8 Hz), 4.14 (1 H, dd, *J* = 4.5, 8.8 Hz), 3.89 (3 H, s), 3.88 (3 H, s), 3.12 (1 H, ddd, *J* = 3.6, 13, 13 Hz); MS, *m/e* (rel intensity) 375 (M<sup>+</sup>, 30), 191 (100); IR (CHCl<sub>3</sub>) 1740, 1715 cm<sup>-1</sup>. Anal. Calcd for C<sub>20</sub>H<sub>25</sub>NO<sub>6</sub>: C, 63.98; H, 6.71; N, 3.75. Found: C, 63.77; H, 6.79; N, 3.82.

**B/C-*trans*-Morphinan 12.** To a stirred solution of **9** (550 mg, 1.0 mmol) in Et<sub>2</sub>O (15 mL) was added *t*-BuOK (111 mg, 1.0 mmol) at -25 °C. After the stirring had been continued at the same temperature for 2 h, the mixture was diluted with aqueous NH<sub>4</sub>Cl and extracted with CH<sub>2</sub>Cl<sub>2</sub>. The extract was worked up to give **10** (430 mg, 79.2% yield) [<sup>1</sup>H NMR (CDCl<sub>3</sub>) δ 8.89 (0.6 H, s), 8.86 (0.4 H, s), 7.31 (4 H, s), 7.26 (6 H, s), 6.78 (3 H, br s), 5.08 (1.2 H, s), 5.03 (0.8 H, s), 4.47 (2 H, s), 3.88 (6 H, br s); MS, *m/e* (rel intensity) 543 (M<sup>+</sup>)] this was used for the following reaction without further purification, since it is sensitive to air. To a stirred solution of **10** (430 mg, 0.79 mmol) in toluene (10 mL) was added BF<sub>3</sub>·Et<sub>2</sub>O (168 mg, 1.18 mmol) at -15 °C. After 0.5 h, the mixture was diluted with 5% NaHCO<sub>3</sub> and extracted with CHCl<sub>3</sub>. The extract was worked up. To a stirred solution of the resulting residue in acetone (10 mL) was added Jones reagent (0.5 mL) under ice-cooling. After 5 min, excess reagent was decomposed with isopropyl alcohol. The mixture was made basic with 5% NaHCO<sub>3</sub> and extracted with CHCl<sub>3</sub>. The extract was worked up, and the remaining residue was chromatographed on silica gel. Elution with hexane-AcOEt (3:1) gave **12** (210 mg, 49.1% yield) as an uncrystallized powder: <sup>1</sup>H (CDCl<sub>3</sub>, 400 MHz) δ 7.54 (5 H, s), 7.35 (10 H, m), 6.77 (1 H, s), 5.17 (2 H, m), 5.85 (1 H, br s), 4.70 (2 H, d, *J* = 11.8 Hz), 4.56 (2 H, d, *J* = 11.8 Hz), 3.94 (3 H, s), 3.92 (3 H, s), 3.76 (1 H, m), *W*<sub>1/2</sub> = 24.8 Hz); MS, *m/e* 541 (M<sup>+</sup>); exact MS calcd for C<sub>33</sub>H<sub>35</sub>NO<sub>6</sub> 541.2462, found 541.2506; IR (CHCl<sub>3</sub>) 1690 cm<sup>-1</sup>.

**6-Hydroxy-B/C-*trans*-morphinan 15.** A mixture of **14** (100 mg, 0.25 mmol), EtOH (10 mL), 12 N HCl (3 drops), and 10% Pd-C (100 mg) was stirred under the atmospheric pressure of H<sub>2</sub> at room temperature for 16 h. After removal of the catalyst by filtration, the solvent was evaporated. The resulting residue was dissolved in 1 N HCl and washed

with Et<sub>2</sub>O. The aqueous layer was made basic with 28% ammonia and extracted with CHCl<sub>3</sub>. The extract was worked up and the resulting residue was chromatographed on silica gel. Elution with CHCl<sub>3</sub>-isopropyl alcohol-28% ammonia (50:5:1) gave **15** (67.4 mg, 85% yield), mp 145–147 °C (Et<sub>2</sub>O-hexane): <sup>1</sup>H NMR (CDCl<sub>3</sub>, 400 MHz), δ 6.78 (1 H, s), 6.63 (1 H, s), 4.03 (1 H, m), 3.85 (3 H, s), 3.84 (3 H, s), 3.11 (1 H, d, *J* = 17.8 Hz), 2.90 (1 H, d, *J* = 5.2 Hz), 2.65 (1 H, dd, *J* = 5.2, 17.8 Hz), 2.34 (3 H, s); MS, *m/e* (rel intensity) 317 (M<sup>+</sup>, 80), 166 (100); IR (CHCl<sub>3</sub>) 3670, 3600, 1610, 1510, 1460 cm<sup>-1</sup>. Anal. Calcd for C<sub>19</sub>H<sub>27</sub>NO<sub>3</sub>: C, 71.89; H, 8.57; N, 4.41. Found: C, 71.55; H, 8.65; N, 4.27.

**6-Oxo-B/C-*trans*-morphinan 16.** A mixture of **15** (63.6 mg, 0.20 mmol), *t*-BuOK (67.5 mg, 0.60 mmol), benzophenone (367 mg, 2.0 mmol), and benzene (5 mL) was heated under reflux for 6 h. The mixture was diluted with benzene and extracted with 1 N HCl. The acidic layer was made basic with 28% ammonia and extracted with CHCl<sub>3</sub>. The extract was worked up to give **16** (50 mg, 80% yield) the <sup>1</sup>H NMR (CDCl<sub>3</sub>, 400 MHz) spectrum of which was identical with that donated from Professor John E. McMurry; MS, *m/e* (rel intensity) 315 (M<sup>+</sup>, 100), 300 (30), 271 (50), 258 (60), 244 (30), 201 (10), 164 (70), 122 (40).

**Acknowledgment.** We are grateful to Professor John E. McMurry for the generous gifts of <sup>1</sup>H NMR and <sup>13</sup>C NMR spectra of authentic sample of 6-oxo-B/C-*trans*-morphinan **16**.

**Registry No.** **1**, 104072-34-6; **2**, 104072-35-7; (±)-**3**, 104072-36-8; (±)-**3** (tributylstannyl)methyl ether, 104072-44-8; **4**, 104072-37-9; **5**, 104072-38-0; (±)-**6**, 104072-39-1; (±)-**7**, 104072-40-4; (±)-**8**, 104072-41-5; (±)-**9**, 104072-42-6; (±)-**10**, 104072-43-7; (±)-**12**, 104072-45-9; (±)-**13**, 104072-46-0; (±)-**14**, 104072-47-1; (±)-**15**, 104072-48-2; (±)-**16**, 104112-75-6; (±)-**17**, 88199-99-9; oxazolidin-2,4-dione, 2346-26-1.

**Supplementary Material Available:** Experimental details for a synthesis of **1**, **2**, **3**, **5**, **7**, **8**, **9**, **13**, and **14** and <sup>1</sup>H NMR (CDCl<sub>3</sub>, 400 MHz) spectral chart on **16** (7 pages). Ordering information is given on any current masthead page.

## Fragmentations and Rearrangements in Organic Synthesis

James B. Hendrickson

Contribution from the Edison Chemical Laboratories, Brandeis University, Waltham, Massachusetts 02254. Received March 28, 1986

**Abstract:** The families of fragmentation and skeletal rearrangement reactions are described and generalized so as to incorporate all variations. This then affords a simple systematic protocol for retrosynthetic mapping of all possible fragmentations and rearrangements onto a target skeleton. The number of such mapping modes suggests that without such a system synthesis planning can easily miss some profitable paths.

In previous discussions of systematic synthesis design,<sup>1</sup> we have focused solely on pathways involving sequential construction reactions and the generation of bondsets to indicate which skeletal bonds to construct. However, many successful short syntheses actually break carbon-carbon bonds as well as construct them. The purpose of the present paper is to explore ways to incorporate such fragmentations efficiently and comprehensively into synthesis design. In principle cleavage of carbon-carbon bonds is retrograde since, in the synthesis of a large target molecule from small starting material pieces, it is only construction reactions which are obligatory. Hence for an efficient synthesis there must be special and compelling reasons for using fragmentation reactions. This probably accounts for the observation that relatively little study

of fragmentations appears in the synthesis literature.

In retrosynthetic analysis of a target skeleton, we delete skeletal bonds in determining which bonds are to be constructed, and this analysis is central to our previous discussions.<sup>1</sup> In seeking carbon-carbon cleavages, or fragmentations, we must add to the skeleton those bonds which are to be broken in the synthesis. Each such addition affords a new target to be dissected in the normal way for construction from smaller starting materials. Since there are so many ways to add new bonds to a skeleton,<sup>2</sup> it is imperative to limit the number of elected fragmentations severely and therefore to provide stringent criteria for assessing profitable ones.

(1) (a) Hendrickson, J. B.; Braun-Keller, E.; Toczko, A. G. *Tetrahedron, Suppl.* **1981**, No. 1, 37, 359. (b) Hendrickson, J. B.; Grier, D. L.; Toczko, A. G. *J. Am. Chem. Soc.* **1985**, *107*, 5228.

(2) The number of ways to add one bond to a skeleton of *n* atoms, *r* rings, and *q* quaternary atoms equals the combinations of (*n* - *q*) atoms two at a time minus existing bonds + 4*q*, or  $N = \frac{1}{2}[n(n-3) + q(q-2n+9)] - r + 1$ . For a bicyclic sesquiterpene (*n* = 15) with one quaternary carbon there are 79 ways to add one more bond.

Table I. Fragmentation Half-Reactions

donors			acceptors		
	substrate	product		substrate	product
$s' = 1$	(A)	$Z=C$	$s' = 1$	(1)	$Z=C$
$s' = 2$	(B)	$C=C$	$s' = 2$	(2)	$C=C$
	(C)	$C=C$		(3)	$C=C$
	(D)	$Z=C$ $Z=CH$		(4)	$C=C$ $CH=C$
	(E)	$C=C$			
	(F)	$Z=C$			

As it is much faster to examine the possible skeletal variants of fragmentations than to assess the detailed chemistry of each one, the present discussion is primarily concerned with systematic protocols for finding all the ways to place fragmentations on a skeleton, i.e., mapping the generalized requirements of fragmentations onto a target or product structure.

**Fragmentation Reactions.** In general terms a fragmentation is the reverse of a construction, and a skeletal rearrangement is a reaction that combines a fragmentation with a construction. These can be described in terms of the abstract reaction description previously introduced<sup>3</sup> to categorize and catalog all organic reactions.<sup>4</sup> In this system each involved carbon in a reaction is understood to have four finds of attachment: H for hydrogen (or other electropositive element), R for  $\sigma$ -bond to carbon,  $\Pi$  for  $\pi$ -bond to carbon, and Z for bond ( $\pi$  or  $\sigma$ ) to electronegative heteroatom. A unit reaction at each involved carbon is then a unit exchange of attachments, expressed by two letters: the first for the attachment bond which is made; the second for the bond broken. Thus of the 16 possible exchanges at any one carbon, the simple fragmentations are HR, ZR, and  $\Pi$ R, while the constructions are RH, RZ, and R $\Pi$ . Of the 10 remaining unit exchanges, all are refunctionalizations (which do not affect the skeleton) except for RR, which implies construction and fragmentation together at the same carbon. Such an exchange is very rare for the intermolecular case (i.e.,  $R + C-R' \rightarrow R-C + R'$ ) except for cyclopropane cleavage. Fragmentations specific to cyclopropanes are omitted in the discussion here. The RR exchange is, however, well-known is skeletal rearrangement reactions, which cleave one carbon-carbon bond and form another at the same carbon, i.e., the migration carbon. These are the rearrangements discussed in later sections below.

The synthetic utility of simple fragmentations may be seen in three skeletal categories. Cleavage of an acyclic carbon-carbon bond is used either to remove an activating or protecting group (as with decarboxylation or cyanohydrin to carbonyl conversion) or to unveil a functional group (as with olefin cleavage to carbonyl). Cleavage of a bond in a monocycle is used to create a pair of functional groups at longer spans, or strand lengths, than those resulting from construction reactions. Cleavage of a common bond in a bicyclic skeleton is used to create medium rings not easily available by simple cyclization.

The first category (acyclic) will not concern us since the function of the cleavage is essentially only that of a refunctionalization or deprotection.<sup>5</sup> The second and third categories bear directly on skeletal analysis for synthesis design. In the second category one examines the target for pairs of functional groups to determine if fragmentation is a reasonable way to create the pair. With respect to functional groups on the target molecule, a key rule of synthesis design states that *their location is more important*

*than their nature.* Thus, any functional group at one carbon is easily transformed into another, but functionalization of an unactivated carbon site is rarely possible with any regiocontrol. When retrosynthetically assessing a pair of function groups on a target skeleton for possible fragmentations, we look primarily for their relative location, i.e., for their distance apart on the skeleton. We define the *strand length* ( $L$ ) as the number of atoms on a skeletal path from one functional group site to the other in a pair. Construction reactions commonly result in strand lengths of 2–5 across the bond constructed, as in Aldol or Claisen constructions of  $L = 3$  and in Michael or Claisen-rearrangement constructions of  $L = 5$ . By contrast, fragmentations which cleave rings of 3–7 members result in functional group pairs of  $L = 4$ –9, often not accessible by construction, as in the pair of carbonyls at  $L = 6$  from ozonolysis of cyclohexenes.

We may systematically generate all possible fragmentations from a mechanistic analysis, moving electron pairs sequentially along a strand of atoms containing a carbon-carbon bond to be cleaved. A generalized strand is shown in eq 1. Each dotted link

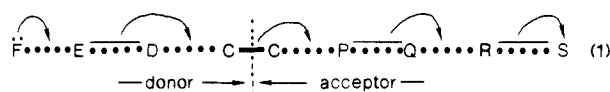

represents a choice of bond or no bond which results in different substrate and product connectivities. With seven dotted links there are  $2^7 = 128$  different skeletal variants of eq 1. Cases with triple bonds do not alter connectivity and are not separately classified, although some real fragmentations result in triple bonds. Furthermore, the outer atoms D–F and P–S may be varied among C, Z, and H, in which Z = electronegative atoms (N, P, O, S, and X) and H electropositive ones (H, B, Si, or M = metal), the latter only acceptable at atoms F, E, P, or R. In examining these combinations, several features serve to eliminate many. Bonds at D–C and C–P must exist since otherwise the cleavage is generated by direct attack on C–C single bond, by nucleophile (D) or electrophile (P), and such reactions are unknown except with highly strained systems like cyclopropanes. Also, several terminal atoms may coalesce into a common reagent or group.

Any fragmentation reaction is the reverse of a construction reaction and like them can be divided into two half-reactions<sup>4</sup> on each side of the bond cleaved, i.e., a donor half, at left in eq 1, and an acceptor half, at the right. The half-span ( $s'$ ) of a fragmentation half-reaction is the number of carbons out from the cleaved bond that change attachments in the reaction. With constructions it is common to observe half-spans of 1–3; the half-reactions of  $s' = 3$  are allylic variants (vinylogues) of those with  $s' = 1$ .<sup>4</sup> The corresponding allylic fragmentation half-reactions (e.g.,  $Z + C=C-C-C$ , or  $\Pi$ I- $\Pi$ I- $\Pi$ R) are essentially unprecedented since other reactions intervene. These are omitted here, so that in eq 1 only atoms D and P may be carbons, i.e.,  $s' = 1, 2$ .

The possible variants of eq 1 which meet these several restrictions are assembled in Table I in the form of half-reactions

(3) Hendrickson, J. B. *J. Am. Chem. Soc.* **1971**, *93*, 6847.

(4) Hendrickson, J. B. *J. Chem. Inf. Comput. Sci.* **1979**, *3*, 129.

(5) The most common fragmentations are acyclic: cleavages of  $C_1$ -units as in decarboxylation, decarbonylation, decyanation, and ozonolysis of terminal olefins to generate active carbonyl groups.

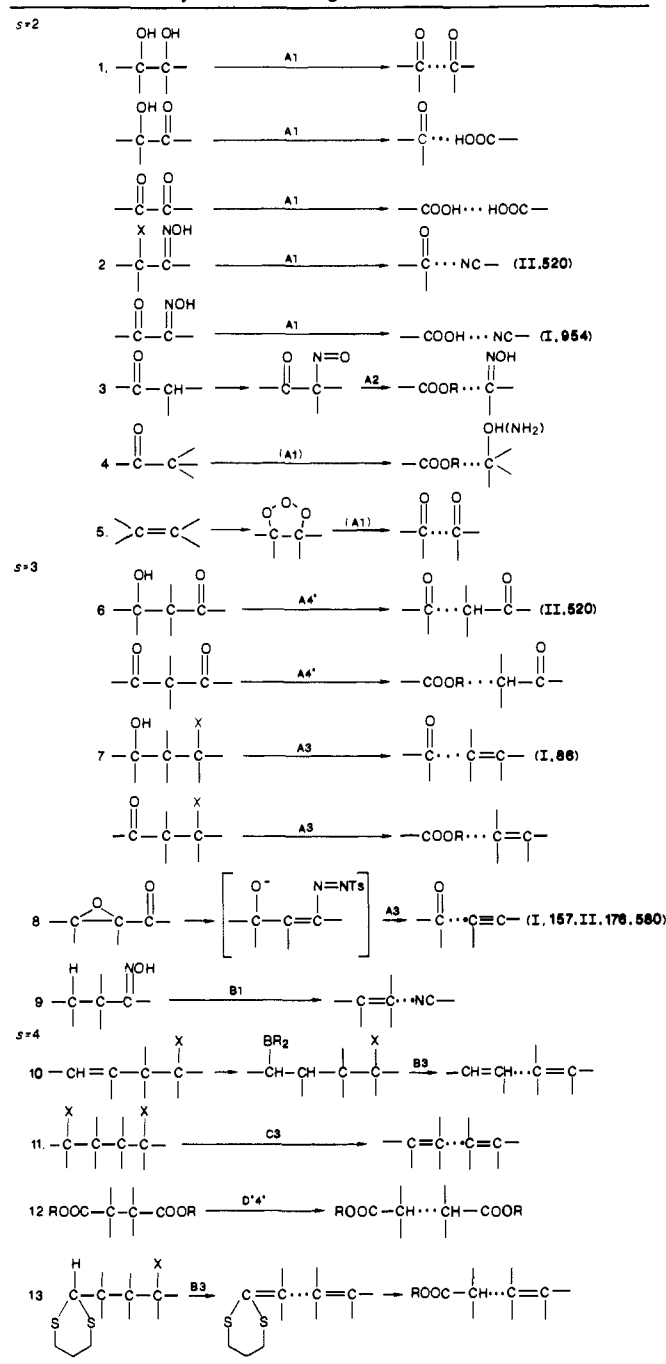
**Table II.** Summary of Known Fragmentations<sup>7</sup>

of *s*' = 1, 2: six donors and four acceptors, which can combine to 24 full fragmentation reactions. Donor A implies release of electrons from heteroatom Z (O, S, N, generally) or base removal of a proton from Z. In donor B the  $\beta$ -H removed by base may be H, BR<sub>2</sub>, SiR<sub>3</sub>, SnR<sub>3</sub>, etc., only the first two of which are common although release of silicon by fluoride is feasible with an adequate acceptor half-reaction. Removal of proton will in practice commonly require an activating adjacent carbonyl or electron-withdrawing heteroatom on the same ( $\beta$ -) carbon, such as nitro, sulfonyl, sulfoxide, phosphonium, phosphoryl, or dithiane. Donors C-F all release a bond to heteroatom, either reductively by metals (C,D) or in more complex cases (E,F) from hetero-hetero groups like hydrazines, hydrazones, oximes, nitrones, *aci*-nitro, etc. The latter cases appear to be unknown.

The acceptor half-reactions are labeled with numbers so that full fragmentations may be described with a letter-number pair. Acceptor 1 is characteristic of leaving groups on nitrogen or oxygen and includes oxidations of alcohols and amines by CrO<sub>3</sub>, HIO<sub>4</sub>, Pb(OAc)<sub>4</sub>, Hg(OAc)<sub>2</sub>, etc., while in acceptor 2 the withdrawing

atom remains attached (nitroso, nitro, sulfonyl, etc.). In the two-carbon cases (*s*' = 2) acceptor 3 represents a simple leaving group in an elimination and acceptor 4 is carbonyl, imine, or nitrile, creating the enol type.

Several of the products can further undergo tautomerization either directly or on reaction workup (hydrolysis) and so these tautomers are included as secondary products. A prime is added to the half-reaction designation for such cases, as in the enol-keto tautomerization of D' and 4' and the analogous protonation of nitro, sulfonyl, etc., in 2'.

We can also generate the set of possible fragmentations another way by creating all possible unit exchanges of attachments attendant on fragmentation. For half-reactions on one or two carbons these are ZR, HR,  $\Pi R \cdot \Pi H$ , and  $\Pi R \cdot \Pi Z$ , and the transformations in Table I are so labeled. Combining these four half-reaction labels all possible ways creates 10 full fragmentations and all but one appear in the donor-acceptor combinations from Table I. The reaction  $\Pi H \cdot \Pi R \cdot \Pi R \cdot \Pi H$ , illustrated in eq 2, is not present, being regarded as mechanistically unrealizable.

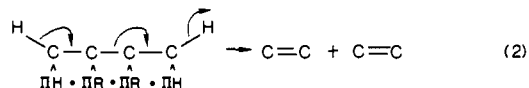

A survey of known fragmentations is presented in Table II, taken from a summary by Corey of those used in the LHASA program<sup>6</sup> and from the summary of Buehler and Pearson.<sup>5,7</sup> The list is arranged by span (*s*), i.e., the number of carbons which change attachments, equal to the sum of the two half-spans of the involved half-reactions ( $s = s_1' + s_2'$ ). Rerfunctionalizations prior or subsequent to the fragmentation are shown where important, and the half-reactions of Table I are noted on the arrows. Of the 24 combinations in Table I, only eight are represented, and most of the known reactions are of the simplest kind (*s* = 2). It would appear that, unlike constructions, there are a number of theoretically possible fragmentations without known examples. This is probably due mainly to the generally unpolarized nature of the C-C bond, making it hard to break.

Nevertheless, there is room for invention by examining possible variants of the several half-reactions in Table I and combining donors and acceptors into full fragmentations with due regard to blocking other, more preferable reaction paths. Thus, for example, the reductive donor half-reactions (C, D) must be done without a proton source and the activation of acceptors by strong leaving groups is more likely to eliminate a C-H bond than a C-C bond if one is available. Some invented reactions from this exercise are illustrated in eq 3-7. It should also be noted that many fragmentations have demanding stereoelectronic requirements (cf., anti-coplanar elimination orientation, etc.). These requirements have the advantage of affording stereocontrol of products and must be considered when applying any fragmentation in synthesis, but they are not addressed in this discussion.

The linear reaction format of eq 1 excludes two kinds of reactions. Rearrangements are formulated differently and discussed later, but rearrangement of a C-C to a C-Z bond is an important fragmentation mode involved in the Schmidt and Baeyer-Villiger reactions shown in example 4 in Table II, synthetically distinguished from the simple *s* = 2 types from Table I by the lack of initiating functionality on one side of the bond cleaved. These can be incorporated into the formalism of eq 1 by having no bond at D...C, i.e., a ( $\overset{Z}{\curvearrowright} \text{C} - \text{C}$ ) donor half-reaction.

Also excluded from the linear format are the pericyclic fragmentations involving four- or six-electron cycles, the former represented by the electrocyclic conversion of cyclobutenes to acyclic dienes and by the vinylcyclopropane rearrangement. The six-electron thermal pericyclic reactions can be generalized for fragmentation as shown in eq 8,<sup>8</sup> with six possible connectivity

(6) Corey, E. J.; Jorgenson, W. L. *J. Am. Chem. Soc.* **1976**, *98*, 202.  
 (7) Buehler, C. A.; Pearson, D. E. *Survey of Organic Synthesis*; Wiley: New York, 1970 (Vol. I), 1977 (Vol. II); pp 1051-1059 (in Index of Vol. II).  
 (8) Hendrickson, J. B. *Angew. Chem., Intl. Ed. Engl.* **1974**, *13*, 47.



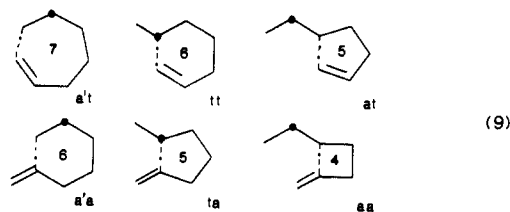
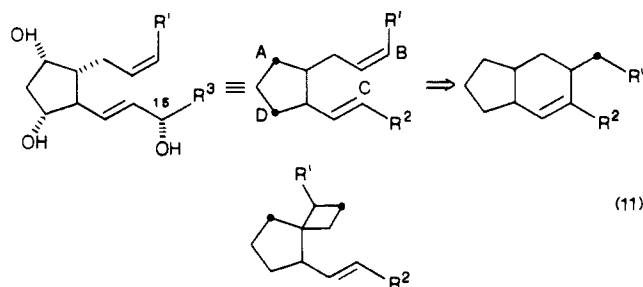
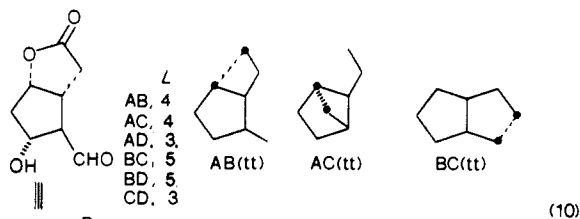

illustration of the use of Table IV. In the actual examples the fragmentations served to control stereochemistry. The pivotal Corey intermediate presents four  $C_1$  sites of functionality (labeled A-D) or six pairs of  $L = 3-5$ , of which the four with  $L > 3$  are examined in eq 10. The fragmentation AB, used by Corey<sup>12</sup> and



others to create cis stereochemistry, is reaction 3, Table II. AC and the lower BC have not been used, although BC could be viable from a cycloaddition, while the upper BC example was used by Turner<sup>13</sup> in a plan which successively cleaved two rings of dicyclopentadiene. Finally, fragmentation BD was also used by Corey<sup>14</sup> and others to cleave a cyclopentadiene cycloadduct. Three-membered rings can also be formed for  $L = 4, 5$ , and one is shown for BC/BD. The same analysis of prostaglandin itself in eq 11 shows six pairs with strands of  $L = 3-7$  among sites A-D (the  $C_{15}$ -OH is ignored since the trans double bond excludes ring formation). We can draw from the chart 23 ways to connect this skeleton to create fragmentation substrates, without including cyclopropane skeletons.

In an elegant and novel short steroid synthesis, Stork<sup>15</sup> recognized the strand of  $L = 6$  in the retroaldol intermediate in eq 12 as a product of tt cleavage of the olefin shown. The many other formal fragmentations that can be placed on this intermediate by using Table IV are all bridged ring systems difficult to synthesize, but the derived olefin itself maps onto an internal Diels-Alder reaction for a very facile overall synthesis.<sup>15</sup>

The isolated olefin stereochemistry in the Cecropia juvenile hormone was seen as controllable via a double fragmentation of a rigid bicyclic in the attractive synthesis by Edwards and Siddall,<sup>16</sup> summarized skeletally in eq 13. Here there are only two func-

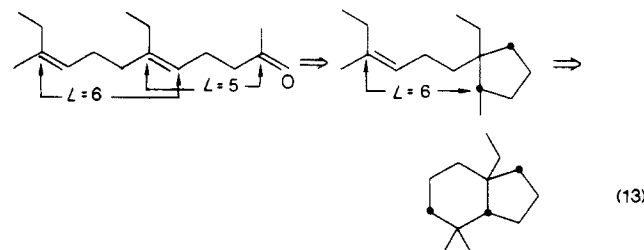
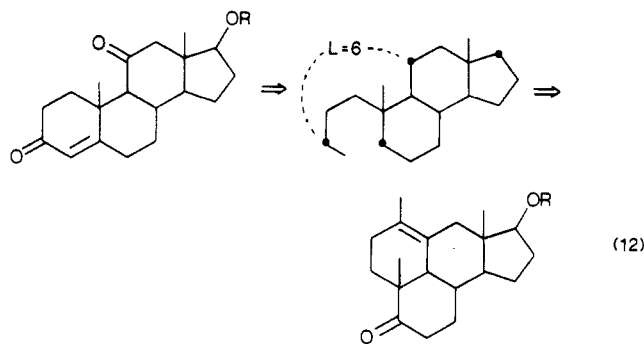

tional group pairs ( $L = 5, 6$ ) with six and four ring connections, respectively, to examine by Table IV, one of which yields the intermediate used. Several others are also viable if the stereochemistry is controlled as it is here.

Finally, the common double fragmentation of unsaturated ketones by oxidation ( $O_3$ ,  $KMnO_4$ , etc.) is not incorporated in Table IV. It may be recognized as a tt connection of two  $C_1$  functionalities with a substrate ring of  $\rho = L + 1$  and is exemplified in the replacement of skeletal carbon by nitrogen in Woodward's classical reserpine synthesis,<sup>17</sup> eq 14.

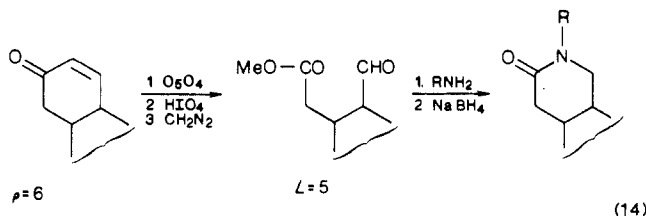

(12) Corey, E. J.; Arnold, Z.; Hutton, J. *Tetrahedron Lett.* **1970**, 307.

(13) Brewster, D.; Myers, M.; Ormerod, J.; Potter, P.; Smith, A. C. B.; Spinner, M. E.; Turner, S. *J. Chem. Soc., Perkin Trans. 1* **1973**, 2796.

(14) Corey, E. J.; Schaaf, T. K.; Huber, W.; Koelliker, O.; Weinshenker, M. *J. Am. Chem. Soc.* **1970**, 92, 397.

(15) Stork, G.; Clark, G.; Shiner, C. S. *J. Am. Chem. Soc.* **1981**, 103, 4948.

(16) Zurfluh, R.; Wall, E. N.; Siddall, J. B.; Edwards, J. A. *J. Am. Chem. Soc.* **1968**, 90, 6224.

(17) Woodward, R. B.; Bader, F. E.; Bickel, H.; Frey, A. J.; Kierstead, R. W. *Tetrahedron* **1958**, 2, 1.

(18) This statement excepts the propellanes in which one bond is common to three rings.

Table IV. Skeletal Relation of Product Functionality to Substrate Ring

product	half-reactions		substrate	recognition form
	donor	acceptor		
ZC...	A	1, 2	ZC-(C-)	
ZCH...	-	2'	ZC-	
ZC-CH...	D'	4'	ZC-C-	
C=C...	{ B C, E	-	CH-C-	
ZC=C...	(B), D, F	3	ZC-C-	
		4		

FG <sub>1</sub> ~~~~~ FG <sub>2</sub>	Q <sub>1</sub> , Q <sub>2</sub>	$\rho = L - (Q_1 + Q_2)$						FRAG types (Table I)	known reactions (Table II)	FRAG span(s)	
		L = 4	L = 5	L = 6	L = 7	L = 8	L = 9				
	a' a'	-1, -1	6	7					D' 4'	(12)	4
	t a'	0, -1	5	6	7				A 4'		3
	a' t	-1, 0	5	6	7				D'(1,2)	6	3
	a' a	-1, +1	4	5	6	7			D' 4'	(12)	4
	t t	0, 0	4	5	6	7			A(1,2)	1-5	2
	a a'	+1, -1	4	5	6	7			D' 4'	(12)	4
	a t	+1, 0	3	4	5	6	7		A4'		
	t a	0, +1	3	4	5	6	7		D'(1,2)	6	3
	a a	+1, +1	-	3	4	5	6	7	D' 4'	12	4
	a' t	-1, 0	5	6	7				(B', D')(3,4)		4
	a' a	-1, +1	4	5	6	7					
	t t	0, 0	4	5	6	7			A(3,4)	7-9	3
	t a	0, +1	3	4	5	6	7		(B-F)(1,2)		
	a t	+1, 0	3	4	5	6	7				
	a a	+1, +1	-	3	4	5	6	7	(B', D')(3,4)	13	4
	t t	0, 0	4	5	6	7					
	t a	0, +1	3	4	5	6	7		(B-F)(3,4)	10,11	4
	a t	+1, 0	3	4	5	6	7				
	a a	+1, +1	-	3	4	5	6	7			

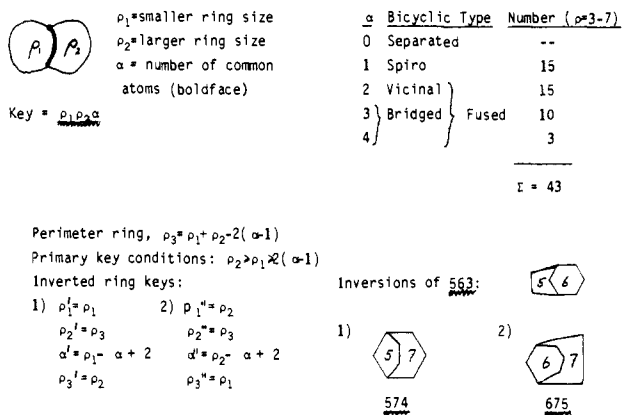

Table V. Monocyclic Rings from Bicyclic Fragmentation

bicyclic precursors	monocycles, $\rho =$					
	7	8	9	10	11	12
vicinal	362, 452	372, 462	472, 562	572, 662	672	772
		552				
bridged	473, 563	573, 663	673	773		
	674	774				

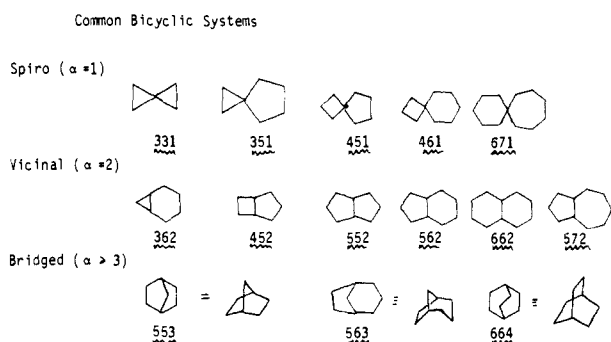

Figure 1. Description system for bicyclics.

ring systems can serve as fragmentation precursors for an eight-membered monocycle.

In order to miss no possible routes, it is important to systematize the generation of bicyclic substrates for a given target ring, based as before on pairs of functional group locations on or about the

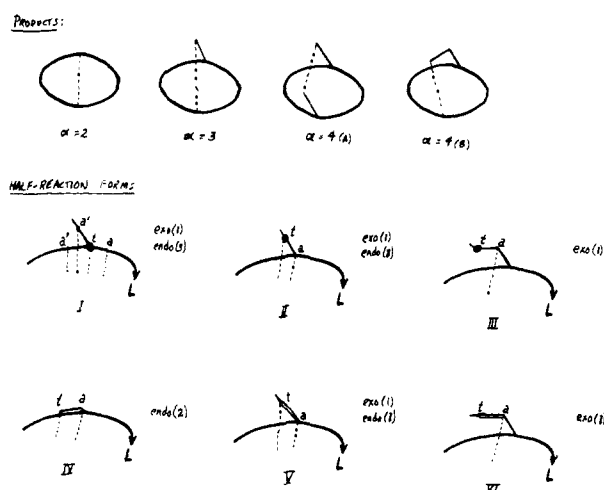

Figure 2. Recognition forms for monocycle synthesis.

target ring. The ways in which a cleavage bond may be placed on a target ring are shown at the top of Figure 2. At the bottom of Figure 2 are shown the two recognition forms used before (Table IV)—the single group and the  $\pi$ -bond—each in three placements on the side of the target ring to allow for all positions of a cleavage bond (dotted) attached either to a ring atom (endo) or to an atom on an exo chain. (The extra placements suitable for creating a

bicyclic substrate of  $\alpha = 4B$  are not shown, owing to the limited utility of those substrates in Table V; they can be created, however, by extending the same process.)

As before, we identify on the target the functional group type and location vis-à-vis the target ring and join dotted sites all ways to generate the bicyclic precursor skeletons. Joining two endo sites creates vicinal precursors ( $\alpha = 2$ ), endo-exo sites join to  $\alpha = 3$ , and two exo sites yield  $\alpha = 4A$  bicyclics. There are a significant number of possible combinations. For endo-endo there are 10 pairings of forms in Figure 2, i.e., I-I, I-II, I-IV, etc., with 32 possible bicyclic ( $\alpha = 2$ ) precursors, while for  $\alpha = 3$  there are 20 endo-exo forms and 35 precursors. The generated substrates for two differently functionalized germacrane sesquiterpene skeletons are shown in Figure 3. The functionality form of the substrates follows from the generalized forms at the top of Table IV:  $C_1$  groups at the same site in target and substrate and target  $\pi$ -bonds generating a  $C_1$ -group in the precursor at one of the target  $\pi$ -sites, the other bearing the cleavage bond.

The bicyclic substrates can thus be easily generated graphically. The bicyclic ring sizes can also be calculated. The target ring size is taken as  $\rho_3$  and the substrate bicyclic ring sizes are given by eq 15. The strand length,  $L$ , is that between the two linked

$$\rho_1 = L - (Q_1 + Q_2) \quad \rho_2 = \rho_3 - \rho_1 + 2(\alpha - 1) \quad (15)$$

functional groups, around the target ring.<sup>19</sup> The values of  $Q$  for each group relate to the cleavage sites (a, t, a' for  $Q = 1, 0, -1$ , respectively) as in Table IV and  $\alpha$  is set by the exo/endo nature of the generated cleavage bond. The examples in Figure 3 can serve to illustrate these quick calculations of  $\rho_1\rho_2\alpha$ . The bond cleaved in those precursors is the ring-junction bond for  $\alpha = 2$  and is marked for  $\alpha = 3$ . The presence of three common bicyclic sesquiterpene precursors (**662** and **572**) among the derived substrates suggests facile starting materials for those synthetic paths.

Among a number of actual syntheses using these fragmentations to forge natural products are the DeClercq-Vandewalle synthesis of damsin<sup>20</sup> utilizing the fragmentation of a **452** bicyclic to a seven-membered ring shown in eq 16, Corey's cleavage of **562** to

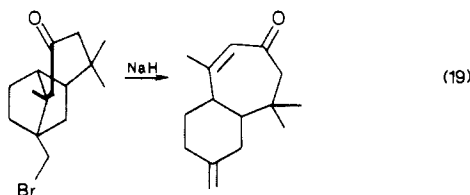
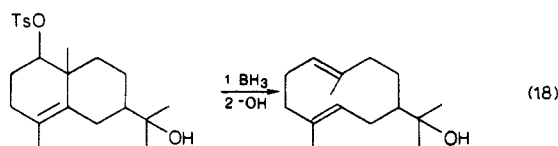
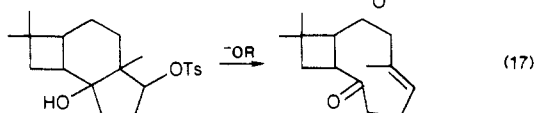
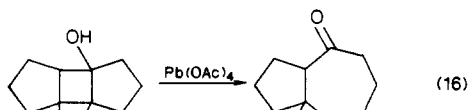

a nine-membered ring for caryophyllene, eq 17,<sup>21</sup> and Wharton's synthesis of hedycaryol,<sup>22</sup> a ten-membered ring via **662** in eq 18. A striking formation of a six-membered ring by cleavage of a **553** bicyclic (eq 19) was reported by Mehta.<sup>23</sup> The pericyclic frag-

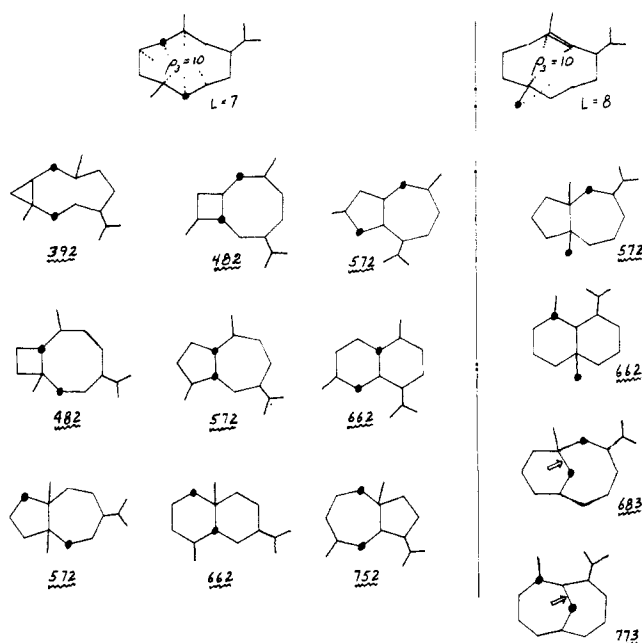

Figure 3. Fragmentation precursors for germacrane skeletons.

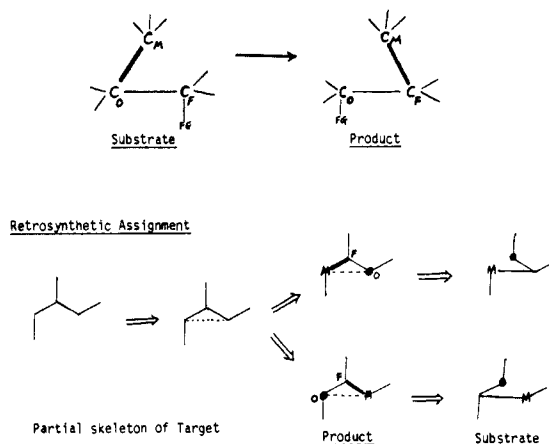

Figure 4. Characterization of rearrangements.

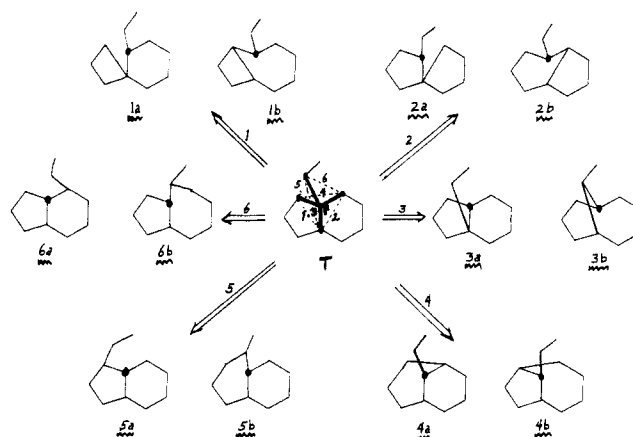

Figure 5. Generation of substrate skeletons for quaternary carbon.

mentation of **662** to a ten-ring (Table III,  $B = 5$ ) was used by Corey,<sup>24</sup> and the pericyclic Cope rearrangement has served to cleave a six-membered ring while creating a ten-membered ring.<sup>25</sup>

**Rearrangements.** The synthetic utility of rearrangements lies largely in ring expansion and contraction and in providing paths

(19) The strand  $L$  may be counted either of two ways around the ring. The carbons the strand includes are those of ring  $\rho_1$  in the substrate.

(20) DeClercq, P.; Vandewalle, M. *J. Org. Chem.* **1977**, *42*, 3447.

(21) Corey, E. J.; Mitra, R. B.; Uda, H. *J. Am. Chem. Soc.* **1964**, *86*, 485.

(22) Wharton, P. S.; Sundin, C. E.; Johnson, D. W.; Kluender, H. C. *J. Org. Chem.* **1972**, *37*, 34.

(23) Mehta, G.; Kapoor, S. K. *J. Org. Chem.* **1974**, *39*, 2618.

(24) Corey, E. J.; Hortmann, A. G. *J. Am. Chem. Soc.* **1965**, *87*, 5736.

(25) Still, W. C. *J. Am. Chem. Soc.* **1977**, *99*, 4186. Grieco, P. A.; Nishizawa, M. *J. Org. Chem.* **1977**, *42*, 1717.

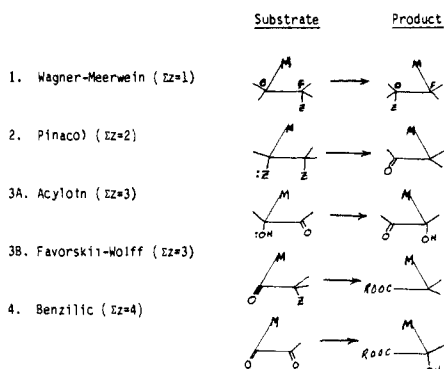

Figure 6. Families of rearrangements by functionality level.

to quaternary carbons, often with a high degree of stereocontrol. The rearrangements considered here are specifically the 1,2-rearrangements of skeleton involving changes in attachments on three carbons, ZR-RR-RZ, oriented in a triangle as shown at the top of Figure 4. The three carbons are labeled O for the original carbon bonded to the migrating carbon (M) and F for the final carbon, bearing the bond to M in the product. When examining a target in retrosynthetic analysis, the protocol is to add a dotted bond across any three linked carbons of the target, regarded as carbons M-F-O, to designate the location of a substrate bond. The carbons at the ends of the dotted line are M and O, either way; carbon O is functionalized and bond F-M is marked as being constructed. The two possible substrates then follow as shown in Figure 4 (lower). Carbon O must either be functionalized in the target or be less than quaternary substituted ( $\sigma < 4$ ) to accommodate a dummy functional group to be removed in the synthesis after rearrangement.

With this protocol there are many ways in which skeletal rearrangements can be mapped onto a target molecule, i.e., twice as many as the triangles that can be drawn onto the skeleton. The number of triangles is  $\sum_i \binom{\sigma_i}{2} = \frac{1}{2} \sum_i \sigma_i (\sigma_i - 1)$ , which is more conveniently calculated from  $\Delta = n + 4r + P + Q - 4$ , where  $n$  = number of atoms,  $r$  = number of rings,  $P$  = number of primary or terminal carbons, and  $Q$  = number of quaternary carbons. Thus on the  $C_{10}$  skeleton of pinene,  $\Delta = 10 + 8 + 3 + 1 - 4 = 18$ , and so 36 rearrangements can be mapped onto the pinene skeleton, generating 36 substrate skeletons (with a marked F-carbon functionalized) which would yield a pinane derivative on rearrangement. Just to create a quaternary carbon by rearrangement requires six triangles with the F carbon as the quaternary and so

12 rearrangement modes. This is illustrated with the 12 substrates for creating the quaternary center in the target ethyl-hydrindane skeleton (T) in Figure 5.

The actual chemistry of rearrangements is conveniently organized by functionality level on carbons O and F and is summarized in Figure 6. The functionality,  $z$ , presents a heteroatom, shown simply as oxygen in some cases. A last rearrangement at  $\Sigma z = 5$  is synthetically trivial since it can bear no further skeletal attachment to carbons O and F. In the pinacol and Favorsky forms rearrangement may be preceded by construction of the O-F bond, as in diazoalkane addition or nitroalkane addition followed by reduction. A few rearrangements either proceed from an olefin or yield an olefin subsequently. These are seen here as equivalent to prior addition followed by one of the five rearrangement modes or as subsequent elimination of the initial product shown in Figure 6. Finally there do not appear to be any known oxidative or reductive rearrangements, i.e., ZR-RR-RH (oxidative) or HR-RR-RZ (reductive).

**Placement of Rearrangements on Cyclic Skeletons.** A primary use of rearrangements in synthesis is to expand or contract rings. Here again we examine bicyclics as containing all possible variants of rearrangements affecting rings in polycyclic molecules. There are eight types of bicyclic rearrangement possible, illustrated in Figure 7. The names reflect the forward reaction but the presentation is retrosynthetic, showing the product first and the substrate as generated ( $\Rightarrow$ ). Each is characterized by a change in the bicyclic key,  $\rho_1 \rho_2 \alpha$ , shown for the retrosynthetic direction, i.e., indicating what changes ( $\Delta \rho, \Delta \alpha$ ) are made to the products to generate the substrates. In skeletal terms, the expansions are the reverse reactions of the contractions. The simple expansion and contraction can occur without involving a second ring and are shown as monocyclic examples in Figure 7.

In order to map the rearrangements onto the bicyclic ring forms, the three atoms M-F-O are assigned in linear order all possible ways onto the atoms of the bicyclic product skeletons. Those cases in which at least one of the three atoms is common to both rings are collected in Figure 8, 34 cases in all. The migrating carbon is marked as M, the M-F bond is in boldface, and carbon O is shown as a dot implying a functional group. Simple expansions and contractions involving only one of the rings are omitted. Each case is shown only for the left ring when either ring can be altered (all but E3, C3) and also each one shown is oriented at the top of the bicyclic; an equivalent one will appear at the bottom, doubling the total if the rings are unsymmetrically substituted. The contraction cases have the exo carbon designed as an O carbon; the reversed form with M at the exo carbon is excluded

	$\Delta \rho_1$	$\Delta \rho_2$	$\Delta \alpha$	Invariant	$\Delta \rho_1$	$\Delta \rho_2$	$\Delta \alpha$	
Simple Expansion (E1)	-1	0	0	$\rho_2 \alpha$	+1	0	0	Simple Contraction (C1)
		0	-1	0		$\rho_1 \alpha$	0	
Complex Expansion (E2)	-1	0	-1	$\rho_2$	+1	0	+1	Complex Contraction (C2)
		0	-1	-1		$\rho_1$	0	
Double Expansion (E3)	-1	-1	-1	—	+1	+1	+1	Double Contraction (C3)
Expansion-Contraction (EC)	-1	+1	0	$\alpha$	+1	-1	0	Contraction-Expansion (CE)

	E1	E2	E3	EC	CE	C3	C2	C1
PRODUCT								
SUBSTRATE								

Figure 7. Types of bicyclic rearrangements.



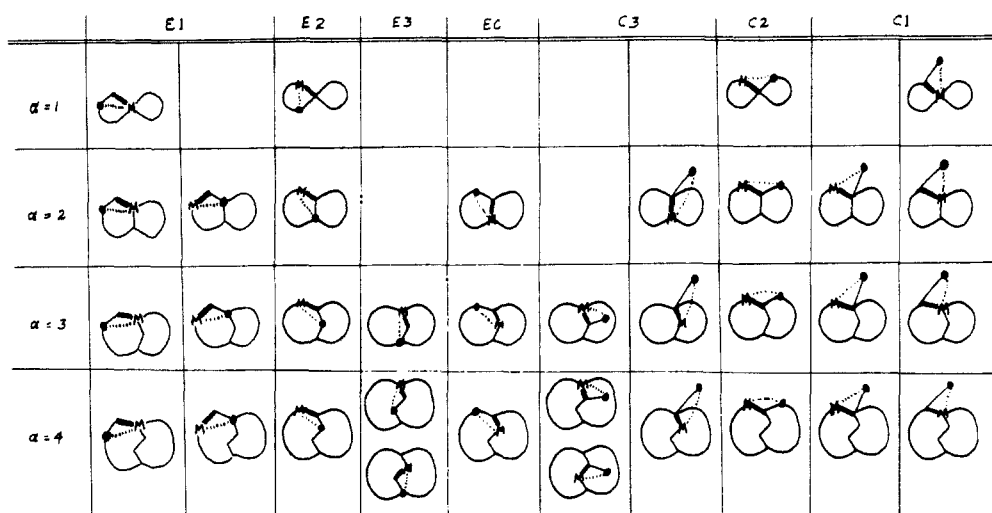
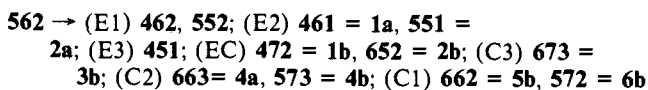

Figure 8. Placement of rearrangements on bicyclic skeletons.

since such a rearrangement only migrates the exo (M) carbon across the ring face without altering the bicyclic skeleton. The generated substrates then follow by breaking the boldface M-F bond, placing functionality on F and making the dotted bond.

The quickest way to appreciate what bicyclic substrates arise from each rearrangement type is simply to apply  $\Delta\rho_1\Delta\rho_2\Delta\alpha$  to each of the 43 bicyclic keys to arrive at the bicyclic key for the substrate for each of the 12 changes summarized in Figure 7. With the variations in Figure 8, the actual number of rearrangement placements on the 43 rings is 962, involving at least one atom in both rings and yielding only rings of  $\rho = 3-7$ . Besides these bicyclic rearrangements there are also 228 expansions (E1) and 378 contractions (C1) involving one ring only, a total of 1568 possible rearrangements on the 43 bicyclics (accepting exo carbons where needed for contractions)! The point of this enumeration is to dramatize the idea that, unless a systematic protocol is used to discover all possible rearrangements for a given system, there may be several synthetic options not considered.

For any given bicyclic skeleton the application of the 12 key changes (Figure 7) generates the keys of the substrates. The placement of the rearranging atoms (M-F-O) will be as shown in the forms of Figure 8. Some substrate keys so generated are unacceptable: if  $\rho = 2$  or if  $\rho_1 < 2(\alpha - 1)$ . In the latter case an inverted key was generated and needs to be reinverted. In that case,  $\rho_1\rho_2\alpha$  is changed to  $\rho_1\rho_3\alpha'$ , where  $\rho_3 = \rho_1 + \rho_2 - 2(\alpha - 1)$  and  $\alpha' = \rho_1 - \alpha + 2$ , as illustrated in Figure 1. Thus a double contraction (C3) of bicyclic 453 would yield 564 which is inverted to 553, and E1 on 473 gives 373, inverted to 362. The examples in Figure 5 chosen to illustrate quaternary carbon formation also afford an example of reordered rings. The 12 key changes on the target (T = 562) are created as follows:



Three of the rearrangements (3a, 5a, 6a) do not alter the ring system, while two key changes (E1) alter the ring system but do not alter the quaternary carbon. The E3 change (to 451) is meaningless since E3 can only function for  $\alpha > 2$  (Figures 5 and 6). The C1 contraction via 572 is found in the synthesis of cyperolone by Hikino.<sup>26</sup>

The 11 key changes for a target perhydroazulene (572) are shown in Figure 9 with the generated substrate bicyclics. The exo carbons required on the target for contractions are now shown and only one possible exo-carbon placement for each of the simple expansions E1 is shown. The perhydroazulene system has been a frequent synthetic target owing to its presence in many natural

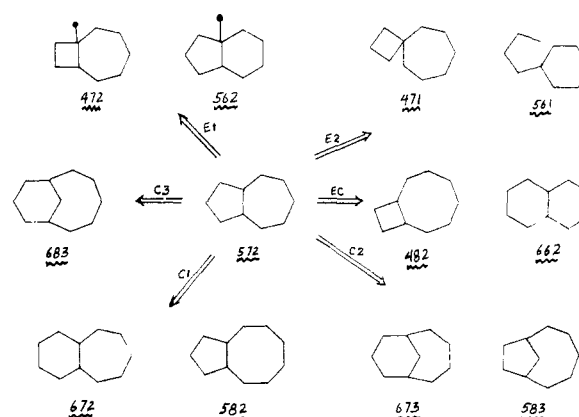

Figure 9. Generation of substrates for perhydroazulenes.

sesquiterpenes.<sup>27</sup> Four of the eleven rearrangements are presented in published syntheses: EC via 662 by Hendrickson<sup>28</sup> and others since,<sup>29</sup> C2 via 673 by Marshall<sup>30</sup> and later by Magnusson,<sup>31</sup> C1 via 672 by Levisalles,<sup>32</sup> and a more complex version of E1 via 562 also by Marshall.<sup>33</sup> Two others appear to be reasonable pathways from accessible substrates: E1 via 472 from (2 + 2) cycloaddition or E2 via 561, a spiro skeleton itself synthesized for several other sesquiterpenes.<sup>34</sup>

**Conclusion.** A systematic approach has been developed here to show that the number of ways in which fragmentations and rearrangements can be applied to synthesis planning is probably much more than is casually appreciated. The systems derived for the two types of reactions allow complete retrosynthetic analysis of given targets so that no options need be missed in planning. The protocols developed are easily applicable to target skeletons by hand and should serve to initiate some new efficient syntheses. They are also directly applicable to computer manipulation and are currently under consideration for incorporation into our SYNGEN program.<sup>1b</sup>

**Acknowledgment.** The receipt of a grant from the National Science Foundation is gratefully acknowledged.

(27) Heathcock, C. H. *The Total Synthesis of Natural Products*, ApSimon, J. Ed.; Wiley: New York, 1973, Vol. 2; 1983, 5.

(28) Hendrickson, J. B.; Ganter, C.; Dorman, D.; Link, H. *Tetrahedron Lett.* 1968, 2235.

(29) Heathcock, C. H.; Delmar, E. G.; Graham, S. L. *J. Am. Chem. Soc.* 1982, 104, 1907.

(30) Marshall, J. A.; Partridge, J. J. *Tetrahedron* 1969, 25, 2159.

(31) Froberg, J.; Magnusson, G.; Thoren, S. *J. Org. Chem.* 1975, 40, 1595.

(32) de Broissia, H.; Levisalles, J.; Rodier, H. *Bull. Soc. Chim. Fr.* 1972, 4314.

(33) Marshall, J. A.; Greene, A. E. *J. Org. Chem.* 1972, 37, 982.

(34) Stork, G.; Danheiser, R. L.; Ganem, B. *J. Am. Chem. Soc.* 1973, 95, 3414.

(26) Hikino, H.; Suzuki, N.; Takemoto, T. *Chem. Pharm. Bull.* 1966, 14, 1441.